

**ALL
IN
ONE**
Same supports for rising by the wheels and by the rocker panel with rubber pads

**TOUT
EN
UN**
Même supports de levage par roues et par tampons sous caisse

master 5000

CARS • VANS • SUVs • PICKUPS • UTILITY TRUCKS



**TODO
EN
UNO**
Mismos soportes para elevación a través de las ruedas y por medio de la chapa de acceso con tacos de goma

**ALLES
IN
EINEM**
Gleiche Aufnahme zum Anheben an den Rädern und am Schweller mit Gummiauflagen

CAPACITY 5000 KG - 11000 LB



**TODO
EM
UM**
Mesmos suportes para elevação através das rodas e por meio do batente inferior com tacos de borracha

**TUTTO
IN
UNO**
Stessi supporti per sollevamento su ruote e su tamponi sottoscocca

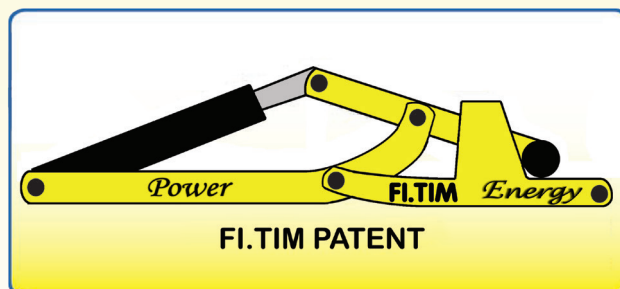

master 5000

NEW PATENT PENDING

CARS • VANS •
SUVS • PICKUPS •
UTILITY TRUCKS

ABOVE GROUND
SUR LE SOL
ÜBERFLUR
SOBRE EL SUELO
SOBRE O SOLO
SOPRA PAVIMENTO

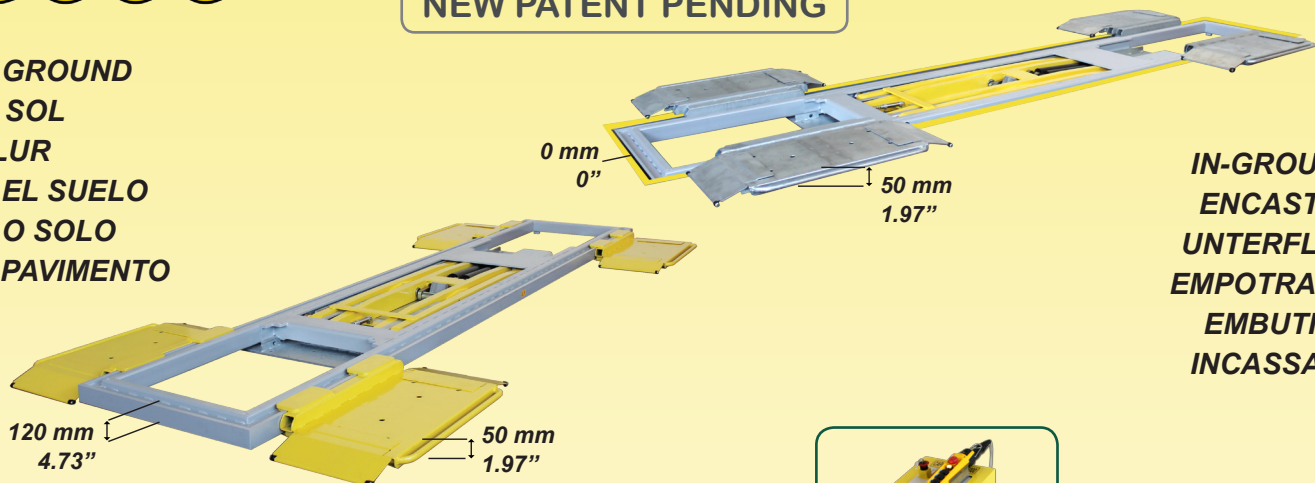

IN-GROUND
ENCASTRE
UNTERFLUR
EMPOTRADO
EMBUTIDO
INCASSATO

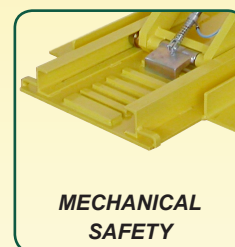
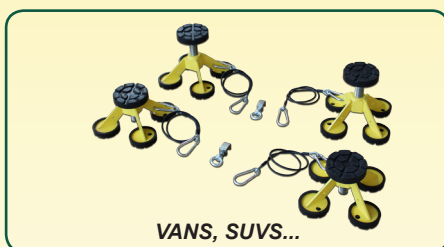

- by the wheels and by the rubber pads
- par roues et par tampons
- an den Rädern und Gummiauflagen

**5000 KG
CAPACITY
11000 LB**

- por las ruedas y por los tacos de goma
- por as rodas e por os tacos de borracha
- su ruote e su tamponi

