



European Patent



American Patent

- FLOOR-MOUNTED BENCHES
- BANCOS SOBRE EL SUELO
- MARBRES DE REDRESSAGE SUR LE SOL
- UBERFLUR RICHTBÄNKE
- BANCOS SOBRE O PAVIMENTO
- BANCHI SOPRAPAVIMENTO

### JOLLIFT<sup>®</sup> 1300 bench

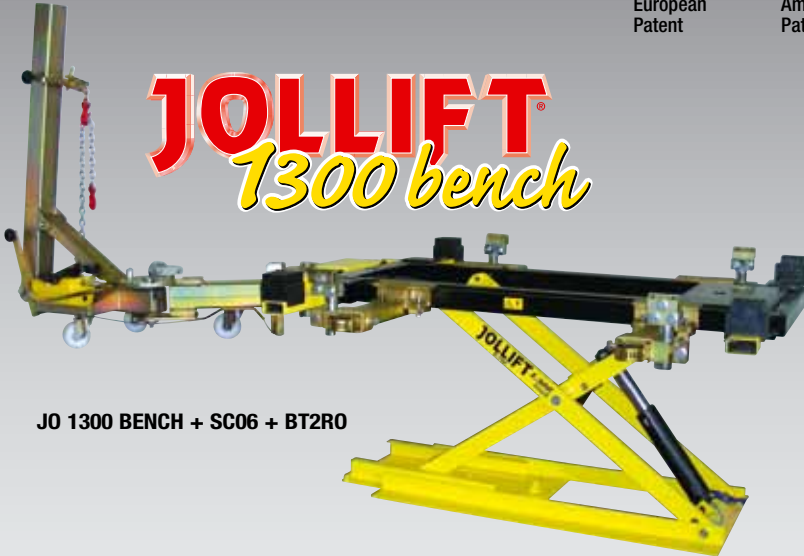

JO 1300 BENCH + SC06 + BT2R0

Max capacity  
kg 2500  
lbs 5500

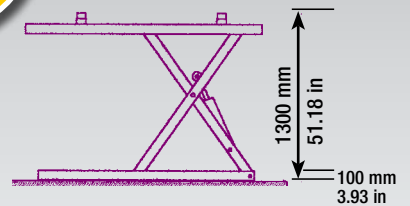

### JOLLIFT<sup>®</sup> master bench



JO MASTER BENCH + FL08 + BT10TON

Max capacity  
kg 3000  
lbs 6600

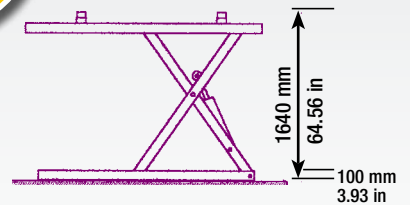

### JOLLIFT<sup>®</sup> 103T

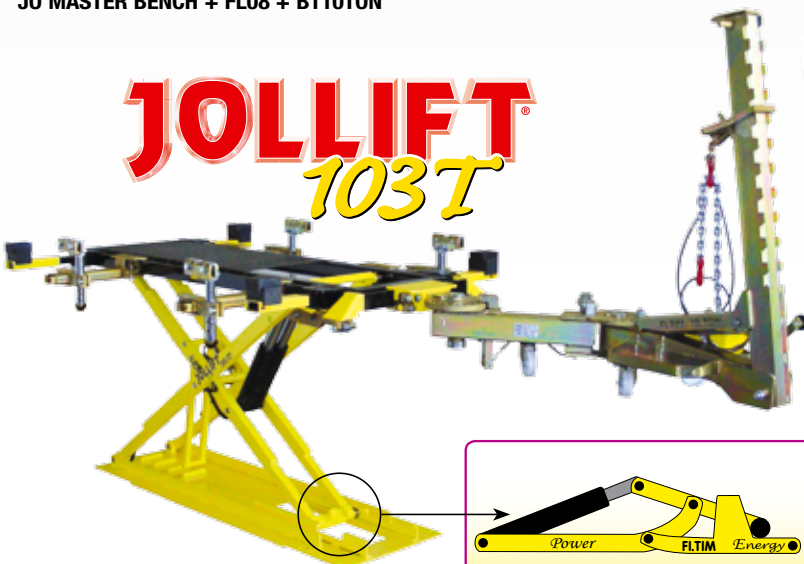

JO 103T + FL08 + BT10TON

Max capacity  
kg 3000  
lbs 6600

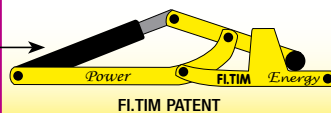
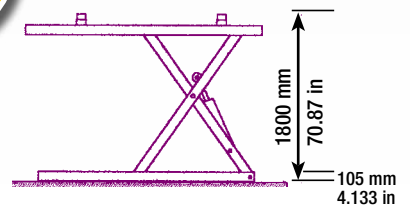

FI.TIM PATENT

- + Performance + Energy Conservation
- + Performances + Économie d'Énergie
- + Prestaciones + Ahorro Energético
- + Leistung + Energieeinsparung
- + Prestações + Poupança Energética
- + Prestazioni + Risparmio Energetico



FL08 CLAMPS  
FL08 KLEMMEN  
PINCES FL08  
MORDAZAS FL08  
MORSE FL08

### JOLLIIFT 1300 bench JOLLIIFT master bench JOLLIIFT 103T

- Folding lifting arms.
- Brazos de elevación plegables
- Bras de soulèvement pliants
- Einklappbare Schwenkarme
- Braços embutidos de elevação
- Bracci di sollevamento richiudibili

- The folding lifting arms and the arm for clamp fastening are independent
- Los brazos de elevación plegables y el brazo para sujeción de la mordaza son independientes
- Les bras pour le soulèvement et les bras pour le fixage des pinces sont indépendants
- Die einklappbaren Schwenkarme und die Arme für Klemmenbefestigung sind unabhängig.
- Os braços embutidos de elevação e os braços dos mordentes são independentes.
- I bracci di sollevamento e i bracci per il fissaggio morse sono indipendenti



- Mechanical safety device
- Seguridad mecánica
- Dispositif de sécurité mécanique
- Mechanische Sicherungseinrichtung
- Segurança mecânica
- Sicurezza meccanica

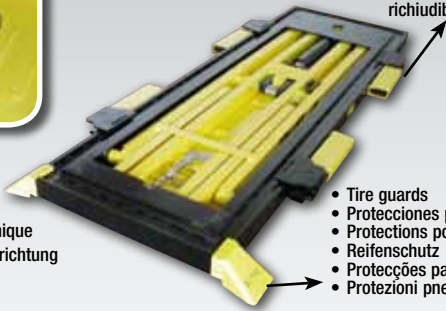

- Tire guards
- Protecciones para neumáticos
- Protections pour pneumatiques
- Reifenschutz
- Protecções para pneumáticos
- Protezioni pneumatici



- Different models of clamps and fastenings are available
- Están disponibles diferentes modelos de mordazas y enclajes
- Ils sont disponibles différents modèles de pinces et fixages
- Verschiedene Modelle von Fahrzeugaufnahmen
- Disponibilidade de diferentes modelos de mordentes e dispositivos de fixação
- Sono disponibili differenti modelli di morse e fissaggi

#### Optional lifting accessories • Accesorios para elevación • Accessoires pour le soulèvement • Hebebühnen Zubehör • Acessoriós para elevação • Accessori per il sollevamento

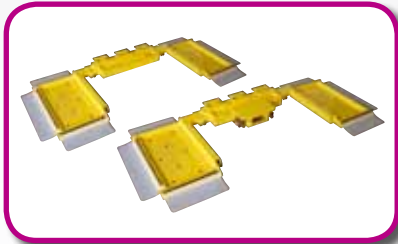

- JO.4P**
- Wheel lifter supports
  - Pemas de apoio de ruedas
  - Plateformes pour roues
  - Plattformen für Räder
  - Plataformas apoio rodas
  - Pedane per ruote



- JO.RUB**
- Adjustable rubber blocks
  - Tacos de goma regulables
  - Tampons réglables
  - Verstellbare Gummiauflagen
  - Tacos com regulação em altura
  - Tamponi regolabili



- JO.M.S. RUB**
- JO.RUB for measuring system
  - JO.RUB para sistemas de medida
  - JO.RUB pour systèmes de mesure
  - JO.RUB für Meßsysteme
  - JO.RUB para sistemas de medição
  - JO.RUB per sistemi di misura

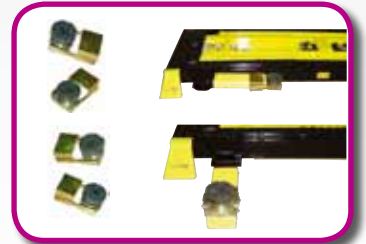

- JO.B90**
- Adjustable rubber block aboard
  - Taco a bordo regulable
  - Tampon à bord réglable
  - An board Verstellbare Gummiauflagen
  - Taco a bordo com regulação
  - Tamponi a bordo regolabili



STANDARD

- Remote control (option)
- Control remoto (accessorio)
- Commande à distance (accessorie)
- Fernbedienung (Zubehör)
- Comando a distancia (accessório)
- Comando a distanza (accessorio)

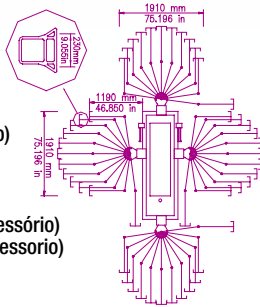

- The traction arm can be fitted all around the plane.
- El brazo de tiro se puede instalar todo alrededor del plano.
- L'équerre de traction peut être installée tout autour au plan.
- Das Zugerät kann rund um die komplette Plattform befestigt werden.
- O braço pode ser fixado em qualquer ponto da plataforma.
- Il braccio di tiro può essere installato tutto intorno al piano.

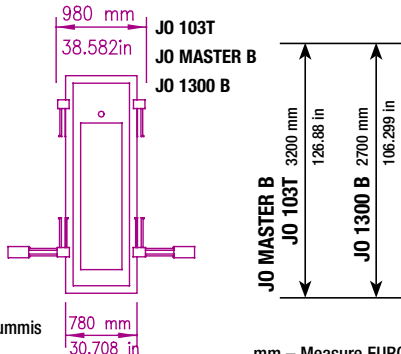
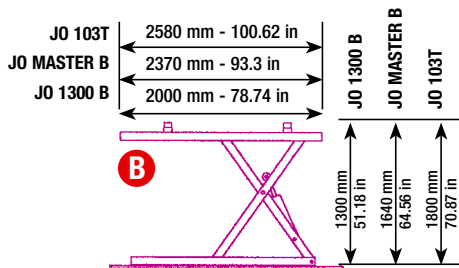

mm – Measure EUROPE – millimetri  
in – Measure USA – inch

- For capacity with wheel lifter supports see specific brochure
- Para capacidad con peanas veáse el prospecto específico
- Pour portée avec plateformes voir la fiche spécifique
- Tragkraft mit Plattformen für Räder, siehe spezieller Prospekt.
- Per portata con pedane vedere scheda specifica

- Measure with double rubber block
- Medida con doble taco de goma
- Measure avec double tampon
- Maße mit doppelten Aufnahmegummi
- Medidas com tacos duplas
- Misura con doppio tampono

- The drawings of JOLLIIFT are registered.
- Los dibujos de JOLLIIFT son registrados.
- Les dessins du JOLLIIFT sont déposés.
- Die Zeichnungen der JOLLIIFT sind registriert.
- Os desenhos do JOLLIIFT estão registrados.
- I disegni di JOLLIIFT sono depositati.